

PRACTIKA
P3



TOPS

25 mm melamine faced chipboard finished with 2 mm matching straight ABS impact resistant edges, anti-scratch-resistant, anti-reflective melamine. MFC density: 670 to 730 kilograms by cubic meter.

Finish options:

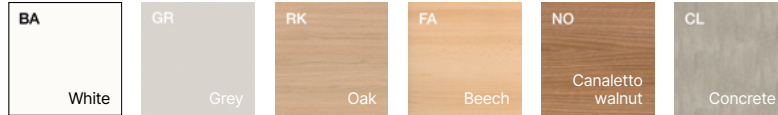

METAL FRAMES

Legs and beams in epoxy powder coated steel tube and sheet.



P3

Finish options:

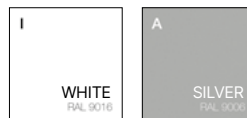

Beams are always supplied in a silver finish.

MOBILE PEDESTAL

Fronts are made of 18mm melamine faced chipboard finished with 1.5mm matching straight ABS impact resistant edge, easy to clean scratch-resistant anti-reflective melamine. Drawer fronts are made of 12.5mm melamine faced chipboard covered with silver PVC and 8mm silver MDF bottom. Metal slides with safety stop mechanism. Central locking with two folding keys. Swivel castors made of black nylon with steel pivot. Pedestals with file drawer are supplied with a fifth anti-tilt castor.

Finish options for fronts and tops:

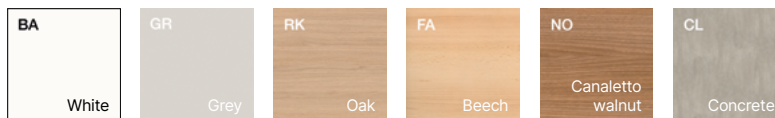

Finish options for carcasses:

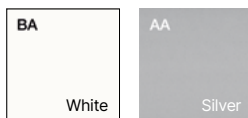

ABS standard handle
Grey



STORAGE

Carcass

Carcass made of melamine faced chipboard, easy to clean scratch-resistant anti-reflective melamine. 25mm top finished with Abs impact resistant edges except the rear edge finished in melamine. 18mm sides and bottom, 8mm back panel, 25mm height adjustable shelves in increments of 32mm. Sides, bottom, back panel and shelves are supplied with matching melamine edges. Five Abs levelling feet that are adjustable from the inside of the unit.

Finish options for carcasses:

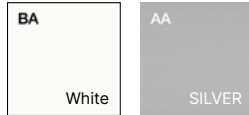

Doors

- Lockable hinged doors made of 18mm melamine faced chipboard finished with 1.5mm matching Abs impact resistant straight edges, easy to clean scratch-resistant anti-reflective melamine. Metal hinges allowing 105° door opening. Lock supplied with two folding keys.
- Lockable frameless glass doors made of 4mm tempered clear glass with polished edges and radius corners. Metal and nylon hinges allowing 90° door opening. Lock supplied with two folding keys.
- Lockable framed glass doors made of 4mm tempered clear glass, 60x18mm melamine coated MDF frame. Metal hinges allowing 105° door opening. Lock supplied with two folding keys.
- Sliding doors made of 18mm melamine faced chipboard finished with 1.5mm matching Abs impact resistant straight edges, easy to clean scratch-resistant anti-reflective melamine. Manually 0-3mm height adjustable Pvc rollers. Lock supplied with two folding keys.

Side filers

Drawer fronts made of 18mm melamine faced chipboard finished with 1.5mm matching Abs impact resistant straight edges, easy to clean scratch-resistant anti-reflective melamine. Pull-out frame made of 0.8mm epoxy powder coated steel in an aluminium finish. 100% extension steel ball bearing runners suitable for 390mm wide A4 suspension files.

Finish options:



P3 BEAM DESK

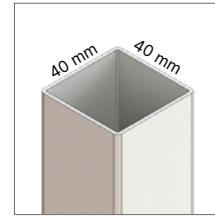
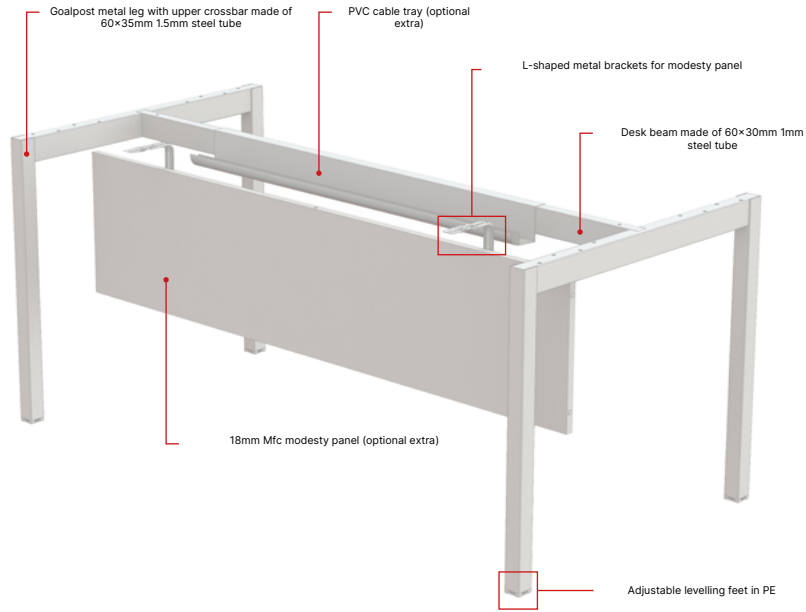

Goalpost legs made of 40x40mm 1.5mm steel tube linked by a 60x35mm 1.5 mm steel beam.

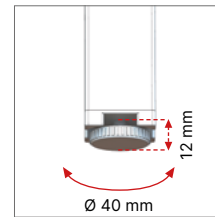

0-12mm adjustable levelling feet made of polyethylene, 40mm diameter.

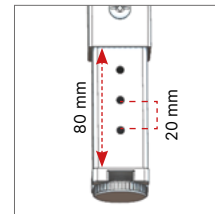

(OPTIONAL EXTRA) Height settable telescopic legs from 679mm to 759mm with increments of 20mm in five positions.

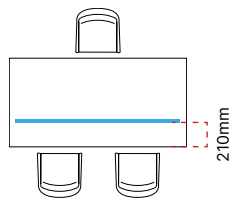

P3 BENCH DESK

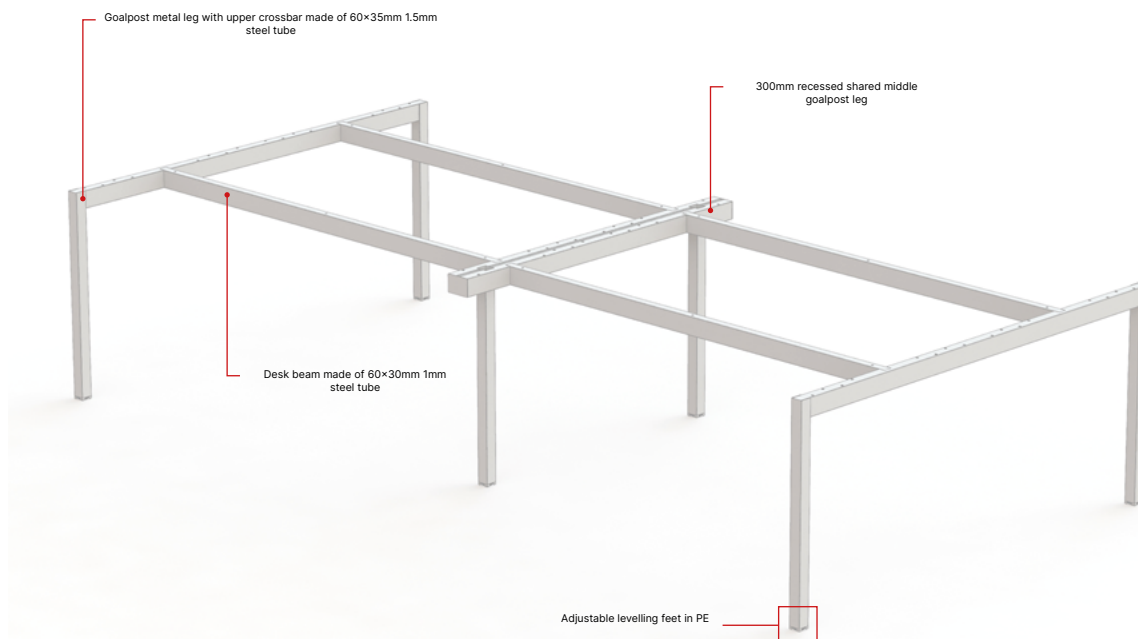

SINGLE DESKS

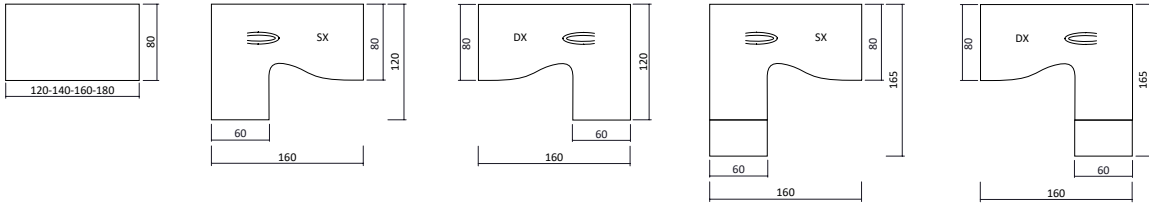

RECTANGULAR RETURN TOP

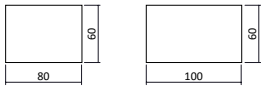

LINKING UNITS



BENCH

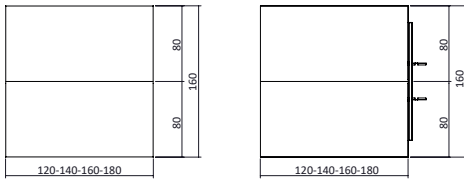

STORAGE

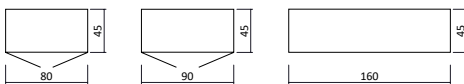

PEDESTALS



SINGLE DESKS

SINGLE DESK

- 1) 25mm desktop
- 2) Static beam
- 3) Structural modesty panel for P1 and P4 frames
- 4) P3 frame
- 5) P2 frame
- 6) P1 frame
- 7) P5 frame
- 8) P4 frame

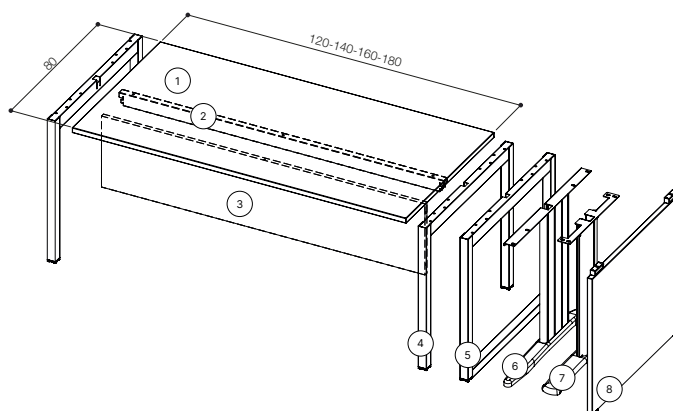

CRESCENT DESK

- 1) Square tubular support leg
- 2) 25mm desktop
- 3) Static beam
- 4) Structural modesty panel for P1 and P4 frames
- 5) P3 frame
- 6) P2 frame
- 7) P1 frame
- 8) P5 frame
- 9) P4 frame

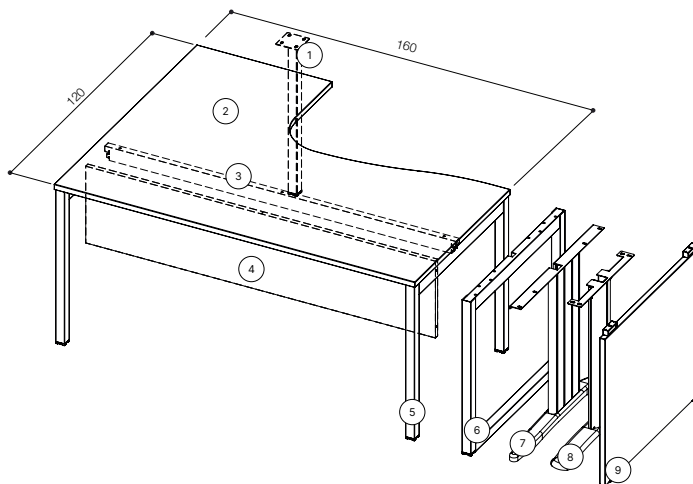

CRESCENT DESK WITH TOP EXTENSION SUPPORTED ON 3-DRAWER STATIC PEDESTAL

- 1) Top supported on static pedestal
- 2) Linking plates for pedestal
- 3) 3-drawer static pedestal
- 4) 25mm desktop
- 5) Static beam
- 6) Structural modesty panel for P1 and P4 frames
- 7) P3 frame
- 8) P2 frame
- 9) P1 frame
- 10) P5 frame
- 11) P4 frame

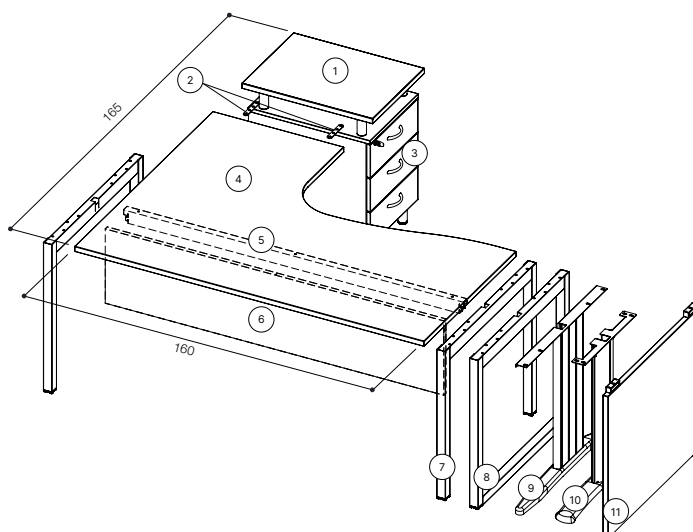

RETURN UNIT

- 1) Linking plates
- 2) 25mm desktop
- 3) Leg for P1, P2, P3 and P4 desks
- 4) P5 leg

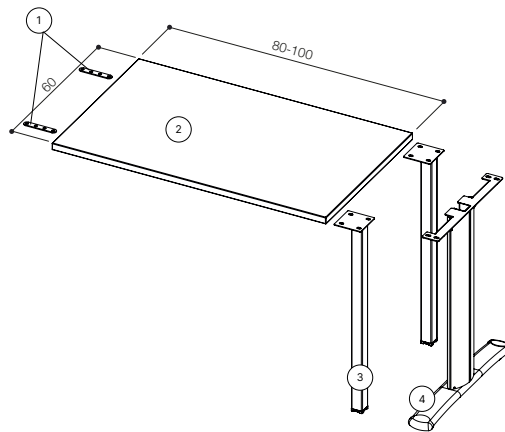

BENCH DESK

- 1) 25mm desktop
- 2) Static beam
- 3) P3 leg for bench desks
- 4) P2 leg for bench desks
- 5) Melamine or fabric frameless screen for bench desks
- 6) U-shaped mounting brackets made from die-cast zamak
- 7) ABS covers

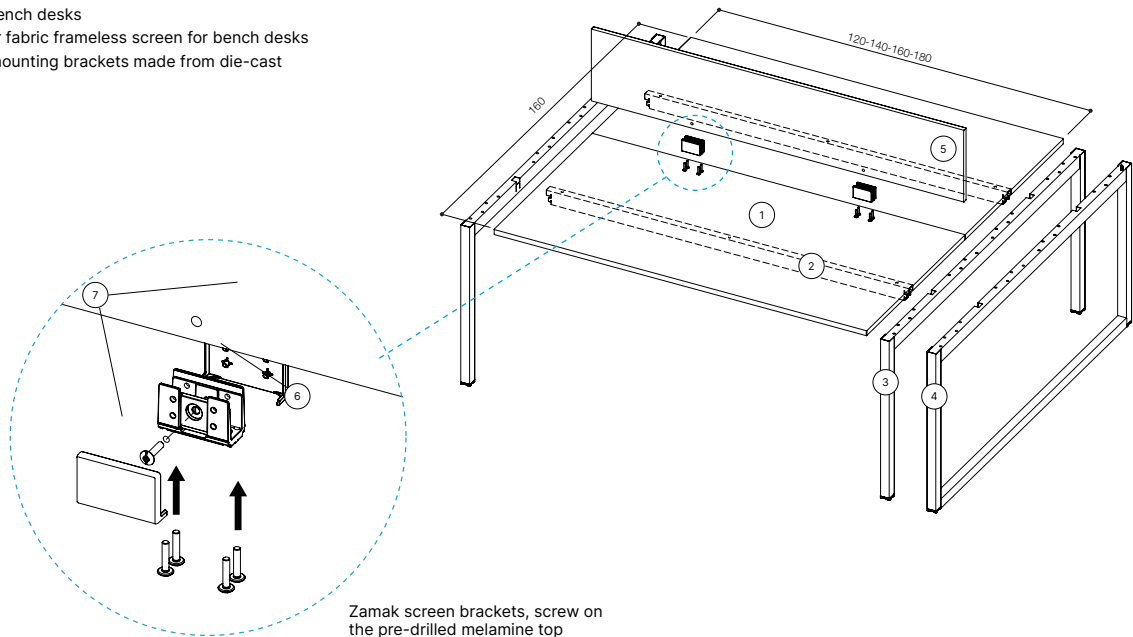

Zamak screen brackets, screw on the pre-drilled melamine top

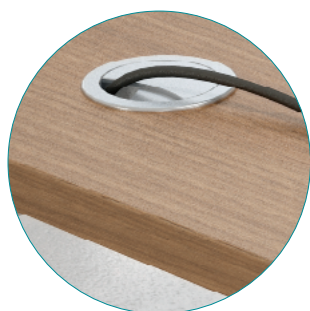

Ø60mm ABS grommet

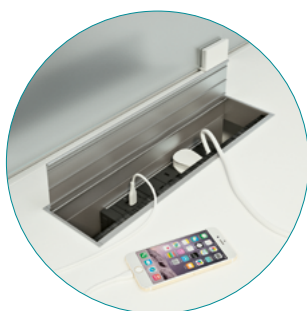

Aluminium cable flap with
open ended cable tray
under

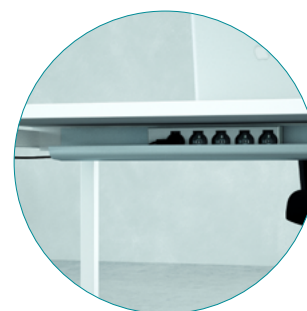

PVC cable tray
(optional extra)

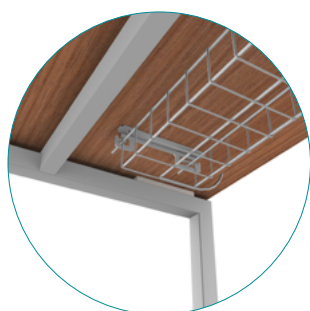

Silver effect steel wire
basket inclusive of
mounting brackets



Melamine modesty panel

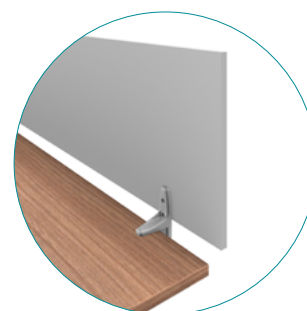





Melamine frameless screen
supplied with clamps to be
fitted to the top



MATERIALS AND RECYCLABILITY

MFC panels used for the Idea+ 01 are solely manufactured with 100% recycled wood and fully meet requisites of formaldehyde low emissions (CATAS certification Quality Award CARB). Rasins used for panels and melamines are free of SVHC substances (to be found in the ECHA list updated as of 12/01/2017).

DESK WITH METAL FRAME

	post-consumer recyclable
 Wood	100%
 Plastic	100%
 Metal	100%
 Mixed	If disposed of in a specialised facilities





STANDARDS

Practika has passed the following tests as certified by the **CATAS** Laboratories in San Giovanni al Natisone - Udine, Italy.

- D.L. 81/2008 Attestazio conformità al D.L. 81/2008
- EN 527-1:2011 Tables and desks dimensions.
- EN 527-2:2002, par 3 Safety mechanical requirements
- EN 527-3:2003, par 5.3 Horizontal static load
- EN 527-3:2003, par 5.2 Vertical static load
- EN 527-3:2003, par 5.4 Horizontal resistance effort
- EN 527-3:2003, par 5.5 Vertical resistance effort
- EN 527-3:2003, par 5.1 Stability
- EN 527-3:2003, par 5.6 Fall
- EN 13721:2004 Surface reflectance
- EN 13722:2004 Surface specular reflection
- EN 1730:2012 Worktops bend
- UNI 9086:1987 Leg impact



CERTIFICATIONS

Constantly receptive to market requirements, Quadrifoglio Sistemi d'Arredo pay special attention on quality and safety contents in order to provide high products and services. The Company has reached certifications UNI EN ISO 9001/2015, UNI EN ISO 14001/2015 and UNI EN ISO 45001/2018 to confirm his policy. Our products are certified and ensured by FSC™ and ECOLOGICAL PANEL.

COMPANY WITH
MANAGEMENT SYSTEM
CERTIFIED BY DNV
ISO 9001 • ISO 14001
ISO 45001



GREEN ENERGY

The Company had installed the photovoltaic system with 4.500 solar panels in a 7.350 m² surface that covers almost entirely the factory. The photovoltaic is able to produce 1Mw of a quiet green energy, that does not harm the environment and is waste-free. With his high production capacity the photovoltaic allows us to reduce emissions in the atmosphere of all those polluting substances and to those that contribute to the greenhouse effects. Consequently, such measures make us save every year 180 tonne of petrol oil, 440 tonne of CO₂, 514kg of sulphur dioxide, 448 kg of nitrogen oxide and 23kg of dust.



TRANSPORT

Packaging is reduced in order to decrease volumes. Goods collections are responsibly managed and organised with the aim of optimise transports, reducing atmosphere emissions.